

# New products

**newLIFE**  
Let's sit together

2023

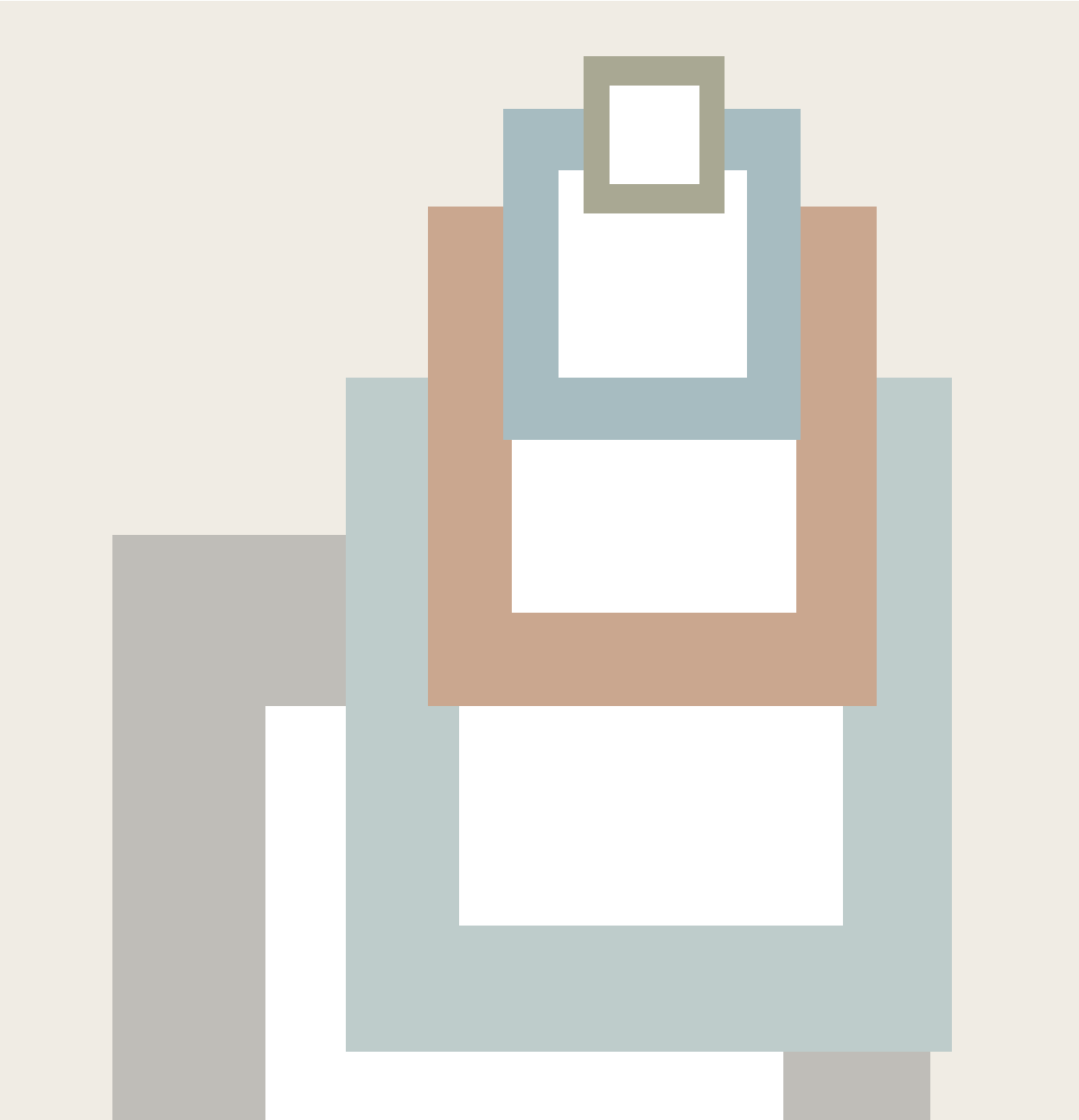



Lala

6

Cara

12

Cara Eco Luna

16

Ottavia

20

Dolcevit Regista

26

And Soft

32



## Sustainability Sostenibilità

**For some years now we have slowly but surely followed a more sustainable path. Initially led by a personal perception, it has taken us into a world where this issue is of crucial importance not only to our generation but to those of the future.**

**Above all we have accepted our social responsibilities; that we are all part of the problem. This does not mean that we cannot do anything, on the contrary, we most certainly can.**

**So why not plan a sustainable path with the declared intention of following the principles of the 3P - People, Planet, Profit, or better said, Prosperity - with a view towards Corporate Social Responsibility - CSR .**

**Our approach to CSR is a positive step, that is in synergy with our business concept of pursuing an innovative business model based on respect.**

**This is why our focus is aimed on sustainability and the environmental impact of our activities.**

Da qualche anno abbiamo intrapreso, lentamente ma inesorabilmente, un percorso sostenibile, inizialmente una percezione personale che ci ha portato, passo dopo passo, in un mondo in cui questo tema è di importanza cruciale per la nostra generazione e per quelle future.

Innanzitutto, ci siamo assunti le nostre responsabilità; siamo tutti parte del problema, ma questo non significa che non possiamo fare nulla.

Allora perché non iniziare a progettare un percorso sostenibile con l'intenzione dichiarata di seguire i principi delle 3P (People, Planet, Profit, o meglio, Prosperity) in un'ottica di CSR o Corporate Social Responsibility.

Un approccio di CSR ci porta ad assumere un comportamento responsabile che, in sinergia con il concetto di business, rappresenta un plus e un prerequisito per perseguire uno sviluppo rispettoso.

Ecco perché cerchiamo di concentrarci sulla sostenibilità e sull'impatto ambientale delle nostre attività.



# Lala P001

Designed by Marco Zito

Dining chair with metal frame, upholstered seat and backrest, stackable. Cheerful and welcoming, light and transversal. Of minimal but solid design and extraordinarily comfortable. Ideal for the most varied needs in the contract sector.

Sedia pranzo fusto metallo, sedile e schienale imbottiti, impilabile. Allegra e accogliente, leggera e trasversale. Dal design minimale ma solida e con uno straordinario comfort. Ideale per le più svariate esigenze in ambito contract.

Il fusto può essere personalizzato con i colori della palette cromatica New Life in nuance o in contrasto con i tessuti dei rivestimenti. A richiesta le imbottiture possono essere certificate Certipur® e i rivestimenti scelti nella categoria green.



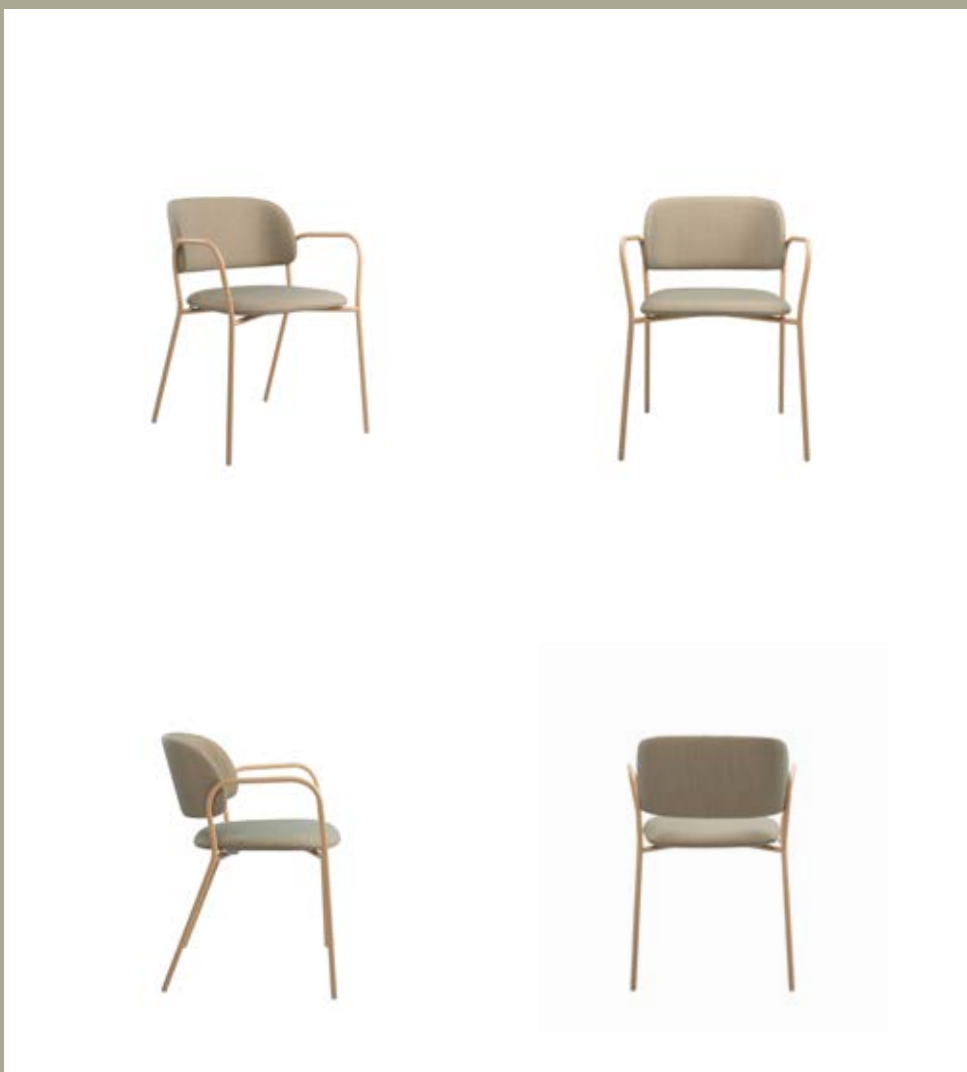



The frame can be customized with the colours of New Life's palette, in nuance or in contrast with the covering fabrics.  
On request, the padding can be Certipur® certified and the coverings chosen in the green category.

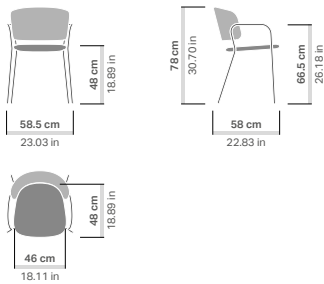

**Fun,  
welcoming,  
vibrant,  
sustainable  
profile,  
softness,  
stackable**



[New life](#) | [New products](#) | [Lala](#)

Allegra,  
accogliente,  
vibrante,  
profilo  
sostenibile,  
morbida,  
impilabile



# Cara BE01

Designed by Alan De La Coba

Nap pod, completely enveloping, it welcomes and isolates from the outer world. It is dedicated to people's well-being. Its cradle-like shape promotes total relaxation, amplified by the sense of isolation created with padding and the use of sound-absorbing coverings. The locally produced dark, solid beech wood base, recalls the shape of a "strong", supporting hand.

Nap pod, poltrona relax, completamente avvolgente, accoglie e isola dal mondo esterno. E' dedicata al benessere delle persone. La sua forma a culla favorisce un relax totale, amplificato dal senso di isolamento creato con le imbottiture e l'utilizzo di rivestimenti fonoassorbenti.

Il basamento in massello di faggio cuorato di produzione locale, ricorda la forma di una mano "forte" che sostiene. Cara Nap Pod rappresenta una perfetta sintesi di comfort ed eleganza, capace di trasmettere un valore aggiunto, al dilà del tempo e delle mode.

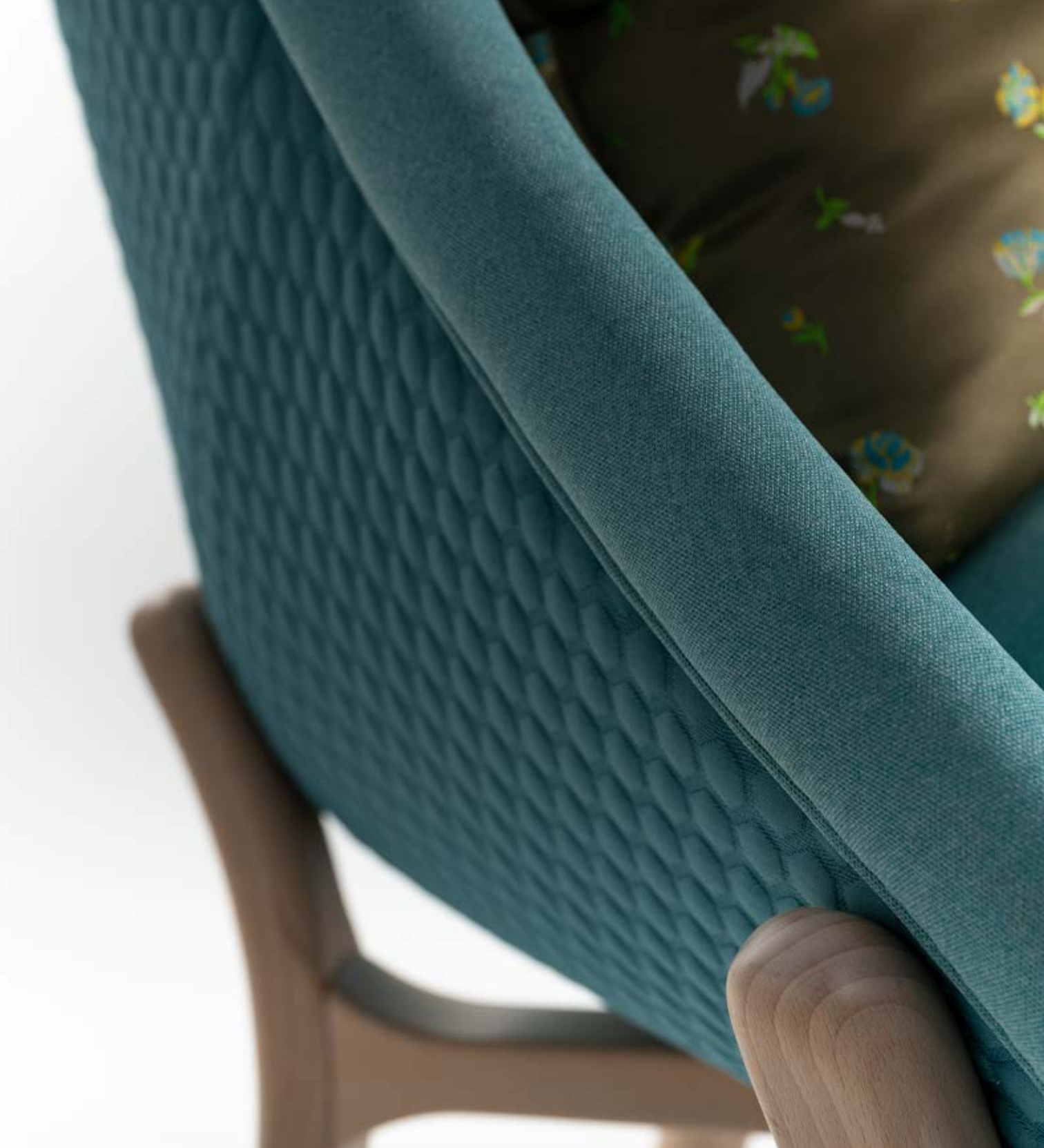



Cara nap pod is an impeccable marriage of comfort and elegance, for added value that goes beyond time and fashion.

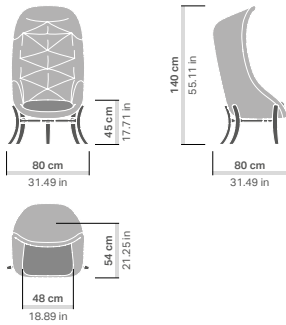

# Cara Eco Luna

Designed by Alan De La Coba

Coffee table. The top was created with an innovative system, by reusing waste from upholstery processing. In a circular economy solution, we reduce textile waste from production, giving it a new life and putting it back into the production cycle.

On demand, it can also be made in beech wood.

It is the perfect furnishing accessory for a classic lounge situation, ensuring chromatic and stylistic continuity with the Cara Nap Pod.

Coffee table. Il piano è stato realizzato con un sistema innovativo, riutilizzando i cascami delle lavorazioni della tappezzeria. In un'ottica di economia circolare, si riduce lo scarto tessile di produzione, dandogli nuova vita e

rimettendolo nel ciclo produttivo. E' il complemento perfetto capace di interpretare una classica situazione lounge, andando in continuità cromatica e stilistica con Cara Nap Pod.



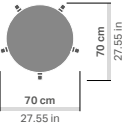
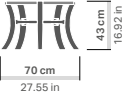

**Well being,  
acoustic  
absorption,  
regional beech,  
covering 100%  
recycled  
from plastic  
bottles**





Benessere,  
assorbimento  
acustico,  
faggio regionale,  
rivestimento 100%  
riciclato da  
bottiglie  
di plastica



# Ottavia

Designed by Alan De La Coba

Dining chair, with or without armrests. Made of solid ash wood, certified FSC®.

Its essential, yet soft of shape, design, generates a piece of seating whose various components can simply be taken apart and recycled at the end of product life.

Sedia pranzo, con e senza braccioli.  
E' realizzata massello di frassino  
certificato FSC®. Il suo design essenziale  
ma dalle forme morbide, crea una seduta

che può essere facilmente scomposta,  
per un più semplice riciclo dei vari  
componenti a fine vita.



**Decomposable  
chair,  
sustainable  
materials,  
certified  
upholstery,  
FSC® solid ash wood,  
removable cushion**



Scomponibile,  
materiali  
riciclabili,  
imbottiture  
certificate,  
legno massello FSC®,  
cuscino removibile







SE01 / SE02

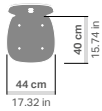
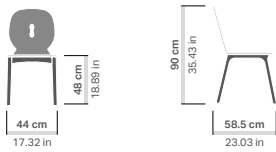

SE02

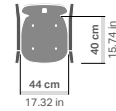
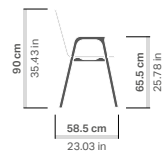
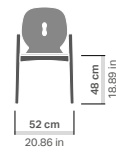

# Dolcevita regista vela P002

Designed by Alan De La Coba

Folding chair for outdoors. Made from recycled sails. Sail fabrics are made from synthetic fibres, that are difficult to dispose of. With these seats we want to give new life to sails that have completed their journey around the world, but which still maintain their exceptional resistance and durability.

The fabric has an AI-created print of a marine seabed, that is manipulated, making it totally exclusive.

Sedia pieghevole per outdoor. E' creata con le vele di riciclo. I tessuti velici sono costituiti da fibre sintetiche il cui smaltimento è oneroso e difficoltoso. Attraverso queste sedute vogliamo dare nuova vita alle vele che nonostante abbiano terminato il loro viaggio in giro per il mondo, mantengono eccezionali proprietà di resistenza e durezza.

L'immagine della stampa è la rappresentazione di un fondale marino creato con l'intelligenza artificiale, poi manipolata per risultare assolutamente esclusiva.

La Dolcevita regista, nelle sue tre versioni, sedia con e senza braccioli e sgabello, viene realizzata anche con tessuti specifici per outdoor.



**Upcycling,  
circular economy,  
recovered sails  
become outdoor  
seating,  
customizable  
sublimation  
printing**

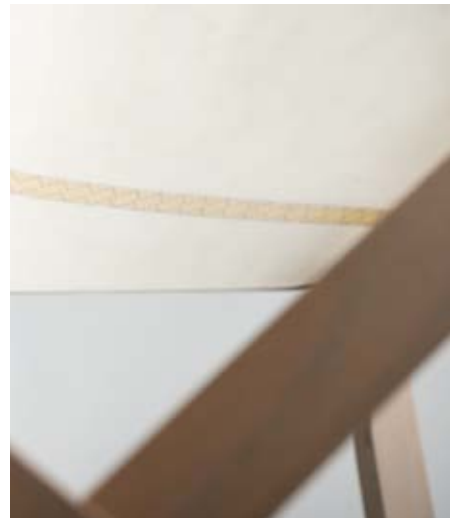



Upcycling,  
economia  
circolare,  
vele di recupero  
diventano sedute  
per l'outdoor,  
stampa sublimatica  
personalizzabile





The Dolcevita regista chair, in its three versions, with and without armrests and stool, is also made with fabrics specifically for outdoor use.

PO01 / PO02

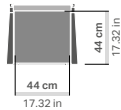
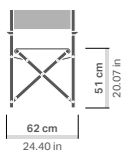

SE01 / SE02

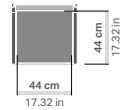
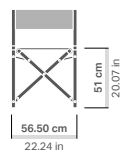

SG01 / SG02

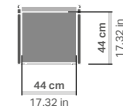
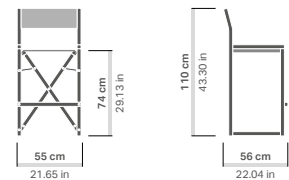

# And soft PLT02

Designed by Alan De La Coba

Fully upholstered lounge chair. "And" is available in a new lounge variant, even softer and more welcoming.

Sinuous lines, enveloping back and even more comfortable seating. "And" is the collection that emboldens you to be experimental and daring, alternating between the manifold functions of the seat

Poltrona lounge completamente imbottita. And si declina in una nuova variante, ancora più morbida e accogliente. Linee sinuose, schienale avvolgente e seduta ancora più comoda. And è la collezione che dà voce alla voglia di sperimentare e osare, spaziando nelle

varie funzionalità delle sedute. Ogni singolo elemento della famiglia ha una propria identità e una propria silhouette, sedute singole per le varianti tonde e anche accostabili nelle varianti squadrate.





**Wrap-  
around  
backrest,  
soft  
volumes,  
green  
upholstery**



[New life](#) | [New products](#) | [And soft](#)

Schienale  
avvolgente,  
volumi  
morbidi,  
rivestimento  
green





Each individual element of the family has its own identity and silhouette; single seats for the round variants but also modular for the square variants.

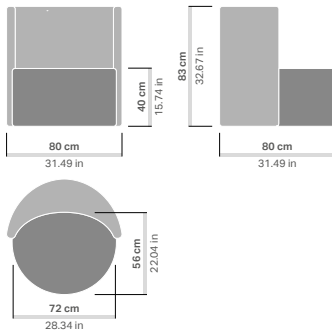

## WOOD ANILINE AND METALS PALETTE

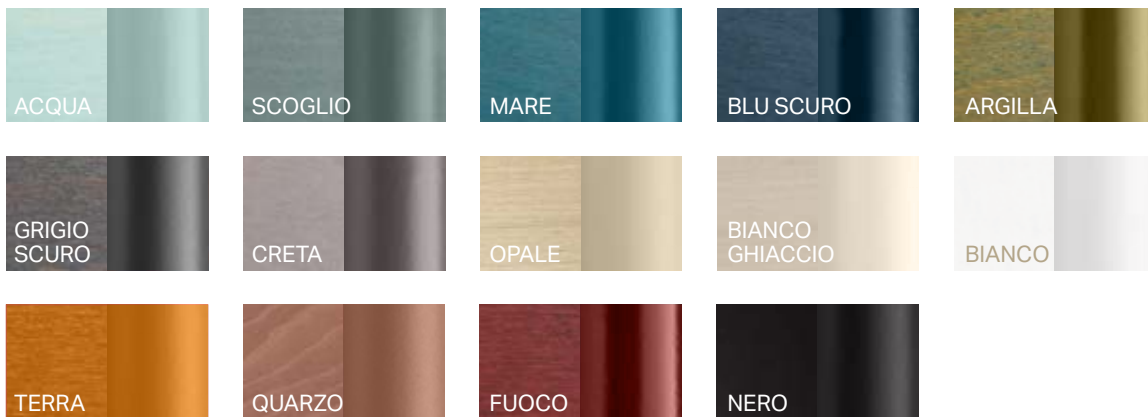

## CLASSIC WOOD COLORS

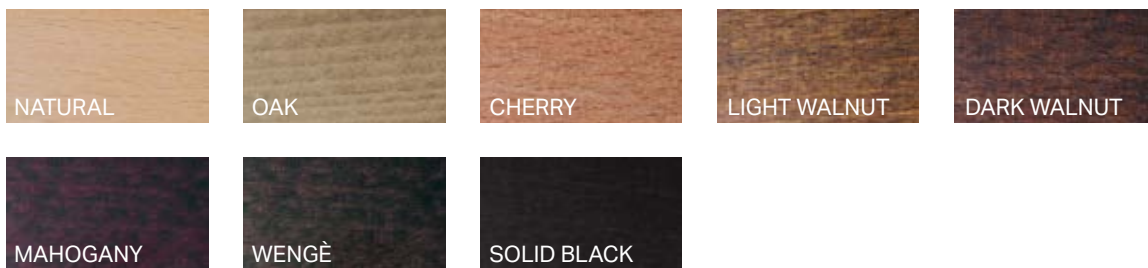

## New Life Finishes Finiture

**Sober and refined nuances, in the colors of classic essences or in the interesting and absolutely exclusive aniline New Life palette, created to satisfy the aesthetic choices of interior and outdoor design.**

**Neutral and delicate or rich and deep tones, in a range where each color complements the other, rendering a measured chromatic balance that has elegance, freshness and modernity.**

**Every nuance is the result of research aimed at giving spaces harmony, identity and continuity.**

Nuance sobrie e raffinate, nei colori delle essenze classiche o nell'interessante e assolutamente esclusiva palette New Life all'anilina, creata per soddisfare le scelte estetiche dell'interior e dell'outdoor design.

Toni neutri e delicati o ricchi e profondi, in una gamma dove ogni colore è complementare all'altro, per offrire un equilibrio cromatico di grande misura, con eleganza, freschezza e modernità.

Ogni nuance è il risultato di una ricerca che tende a dare armonia, identità e continuità agli spazi.





**New Life srl**

Via Sottorive, 5/7 33048  
San Giovanni al Natisone (Udine) Italy

[www.newlifecontract.com](http://www.newlifecontract.com)  
[info@newlifecontract.com](mailto:info@newlifecontract.com)  
phone: + 39 0432 746518



# New products

**newLIFE**  
Let's sit together

2023

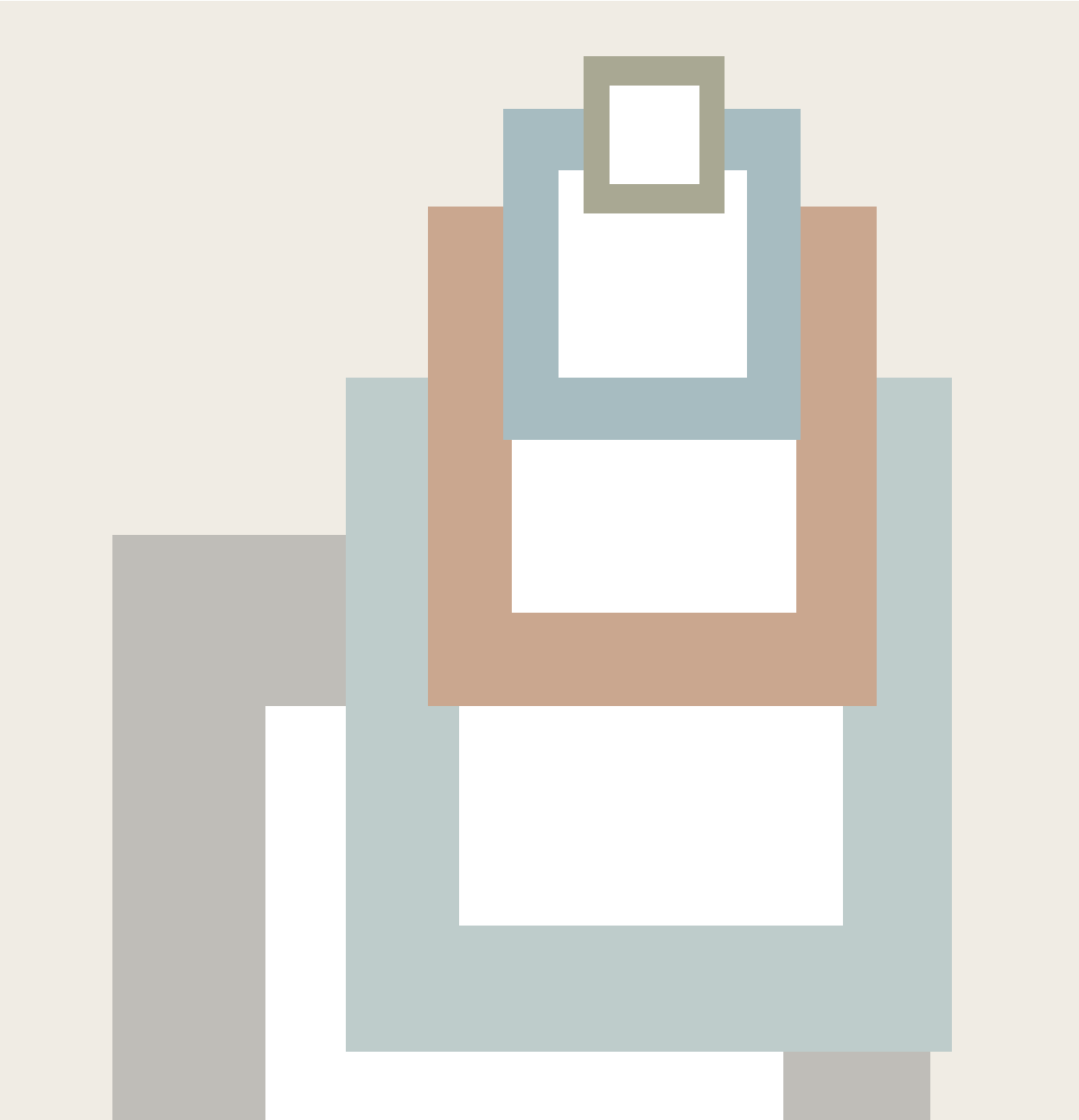



Lala

6

Cara

12

Cara Eco Luna

16

Ottavia

20

Dolcevit Regista

26

And Soft

32



## Sustainability Sostenibilità

**For some years now we have slowly but surely followed a more sustainable path. Initially led by a personal perception, it has taken us into a world where this issue is of crucial importance not only to our generation but to those of the future.**

**Above all we have accepted our social responsibilities; that we are all part of the problem. This does not mean that we cannot do anything, on the contrary, we most certainly can.**

**So why not plan a sustainable path with the declared intention of following the principles of the 3P - People, Planet, Profit, or better said, Prosperity - with a view towards Corporate Social Responsibility - CSR .**

**Our approach to CSR is a positive step, that is in synergy with our business concept of pursuing an innovative business model based on respect.**

**This is why our focus is aimed on sustainability and the environmental impact of our activities.**

Da qualche anno abbiamo intrapreso, lentamente ma inesorabilmente, un percorso sostenibile, inizialmente una percezione personale che ci ha portato, passo dopo passo, in un mondo in cui questo tema è di importanza cruciale per la nostra generazione e per quelle future.

Innanzitutto, ci siamo assunti le nostre responsabilità; siamo tutti parte del problema, ma questo non significa che non possiamo fare nulla.

Allora perché non iniziare a progettare un percorso sostenibile con l'intenzione dichiarata di seguire i principi delle 3P (People, Planet, Profit, o meglio, Prosperity) in un'ottica di CSR o Corporate Social Responsibility.

Un approccio di CSR ci porta ad assumere un comportamento responsabile che, in sinergia con il concetto di business, rappresenta un plus e un prerequisito per perseguire uno sviluppo rispettoso.

Ecco perché cerchiamo di concentrarci sulla sostenibilità e sull'impatto ambientale delle nostre attività.



# Lala P001

Designed by Marco Zito

Dining chair with metal frame, upholstered seat and backrest, stackable. Cheerful and welcoming, light and transversal. Of minimal but solid design and extraordinarily comfortable. Ideal for the most varied needs in the contract sector.

Sedia pranzo fusto metallo, sedile e schienale imbottiti, impilabile. Allegra e accogliente, leggera e trasversale. Dal design minimale ma solida e con uno straordinario comfort. Ideale per le più svariate esigenze in ambito contract.

Il fusto può essere personalizzato con i colori della palette cromatica New Life in nuance o in contrasto con i tessuti dei rivestimenti. A richiesta le imbottiture possono essere certificate Certipur® e i rivestimenti scelti nella categoria green.



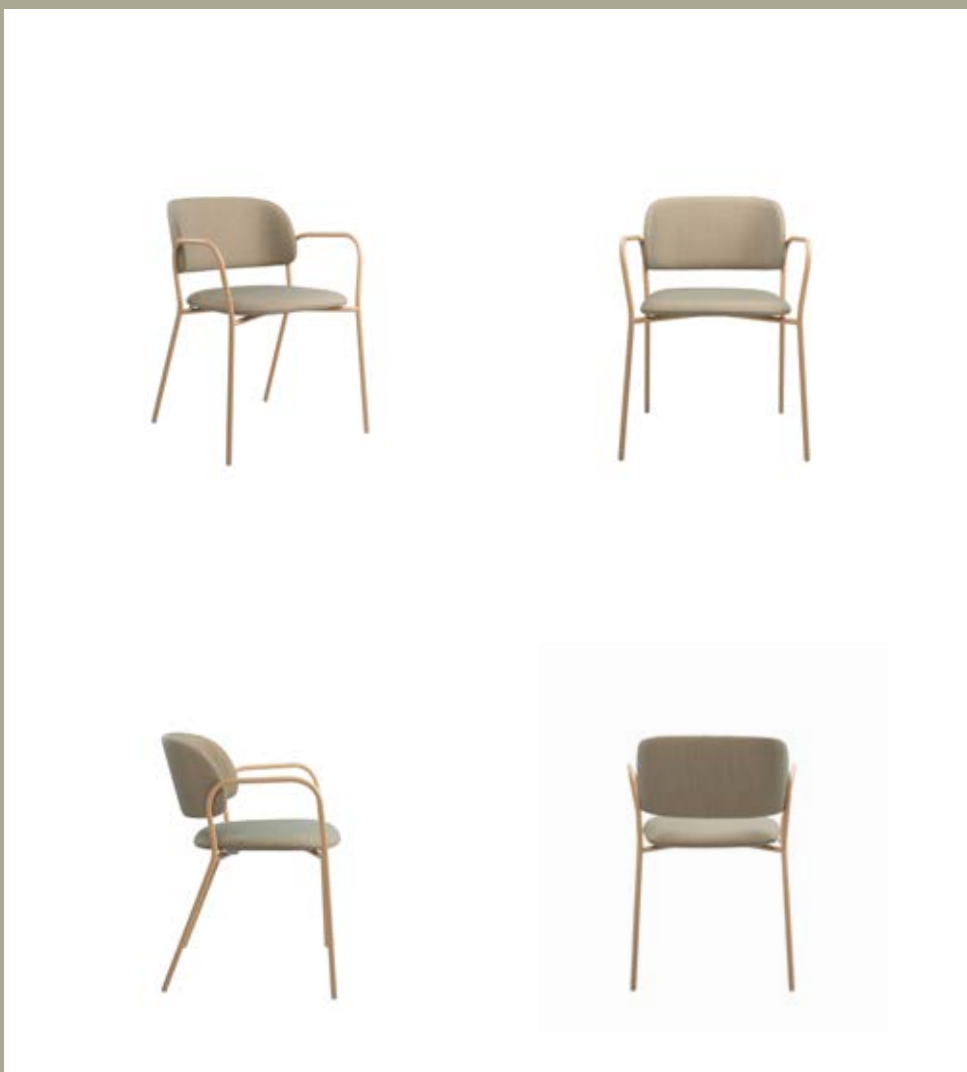



The frame can be customized with the colours of New Life's palette, in nuance or in contrast with the covering fabrics.  
On request, the padding can be Certipur® certified and the coverings chosen in the green category.

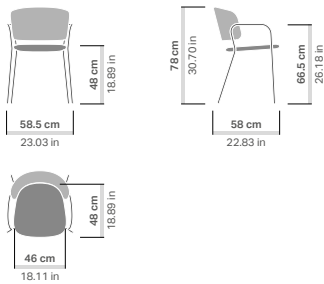

**Fun,  
welcoming,  
vibrant,  
sustainable  
profile,  
softness,  
stackable**



[New life](#) | [New products](#) | [Lala](#)

Allegra,  
accogliente,  
vibrante,  
profilo  
sostenibile,  
morbida,  
impilabile



# Cara BE01

Designed by Alan De La Coba

Nap pod, completely enveloping, it welcomes and isolates from the outer world. It is dedicated to people's well-being. Its cradle-like shape promotes total relaxation, amplified by the sense of isolation created with padding and the use of sound-absorbing coverings. The locally produced dark, solid beech wood base, recalls the shape of a "strong", supporting hand.

Nap pod, poltrona relax, completamente avvolgente, accoglie e isola dal mondo esterno. E' dedicata al benessere delle persone. La sua forma a culla favorisce un relax totale, amplificato dal senso di isolamento creato con le imbottiture e l'utilizzo di rivestimenti fonoassorbenti.

Il basamento in massello di faggio cuorato di produzione locale, ricorda la forma di una mano "forte" che sostiene. Cara Nap Pod rappresenta una perfetta sintesi di comfort ed eleganza, capace di trasmettere un valore aggiunto, al dilà del tempo e delle mode.

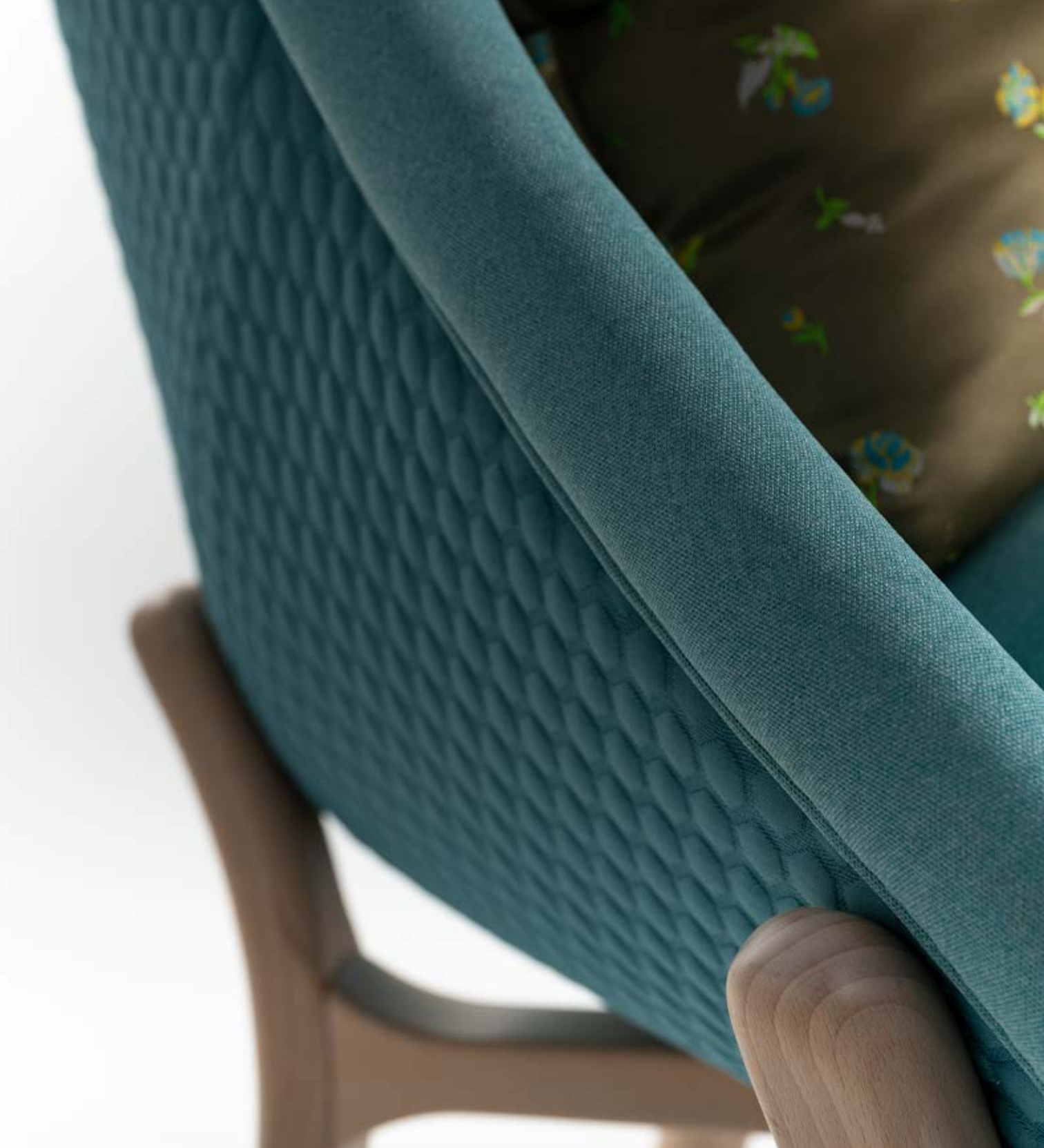



Cara nap pod is an impeccable marriage of comfort and elegance, for added value that goes beyond time and fashion.

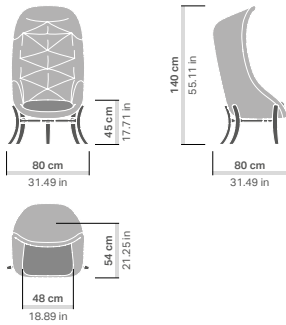

# Cara Eco Luna

Designed by Alan De La Coba

Coffee table. The top was created with an innovative system, by reusing waste from upholstery processing. In a circular economy solution, we reduce textile waste from production, giving it a new life and putting it back into the production cycle.

On demand, it can also be made in beech wood.

It is the perfect furnishing accessory for a classic lounge situation, ensuring chromatic and stylistic continuity with the Cara Nap Pod.

Coffee table. Il piano è stato realizzato con un sistema innovativo, riutilizzando i cascami delle lavorazioni della tappezzeria. In un'ottica di economia circolare, si riduce lo scarto tessile di produzione, dandogli nuova vita e

rimettendolo nel ciclo produttivo. E' il complemento perfetto capace di interpretare una classica situazione lounge, andando in continuità cromatica e stilistica con Cara Nap Pod.



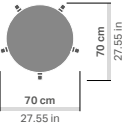
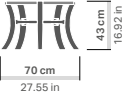

**Well being,  
acoustic  
absorption,  
regional beech,  
covering 100%  
recycled  
from plastic  
bottles**





Benessere,  
assorbimento  
acustico,  
faggio regionale,  
rivestimento 100%  
riciclato da  
bottiglie  
di plastica



# Ottavia

Designed by Alan De La Coba

Dining chair, with or without armrests. Made of solid ash wood, certified FSC®.

Its essential, yet soft of shape, design, generates a piece of seating whose various components can simply be taken apart and recycled at the end of product life.

Sedia pranzo, con e senza braccioli.  
E' realizzata massello di frassino  
certificato FSC®. Il suo design essenziale  
ma dalle forme morbide, crea una seduta

che può essere facilmente scomposta,  
per un più semplice riciclo dei vari  
componenti a fine vita.



**Decomposable  
chair,  
sustainable  
materials,  
certified  
upholstery,  
FSC® solid ash wood,  
removable cushion**



Scomponibile,  
materiali  
riciclabili,  
imbottiture  
certificate,  
legno massello FSC®,  
cuscino removibile







SE01 / SE02

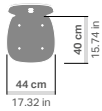
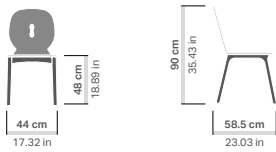

SE02

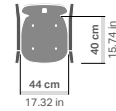
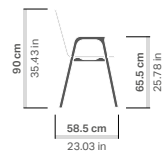
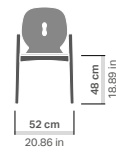

# Dolcevita regista vela P002

Designed by Alan De La Coba

Folding chair for outdoors. Made from recycled sails. Sail fabrics are made from synthetic fibres, that are difficult to dispose of. With these seats we want to give new life to sails that have completed their journey around the world, but which still maintain their exceptional resistance and durability.

The fabric has an AI-created print of a marine seabed, that is manipulated, making it totally exclusive.

Sedia pieghevole per outdoor. E' creata con le vele di riciclo. I tessuti velici sono costituiti da fibre sintetiche il cui smaltimento è oneroso e difficoltoso. Attraverso queste sedute vogliamo dare nuova vita alle vele che nonostante abbiano terminato il loro viaggio in giro per il mondo, mantengono eccezionali proprietà di resistenza e durezza.

L'immagine della stampa è la rappresentazione di un fondale marino creato con l'intelligenza artificiale, poi manipolata per risultare assolutamente esclusiva.

La Dolcevita regista, nelle sue tre versioni, sedia con e senza braccioli e sgabello, viene realizzata anche con tessuti specifici per outdoor.



**Upcycling,  
circular economy,  
recovered sails  
become outdoor  
seating,  
customizable  
sublimation  
printing**

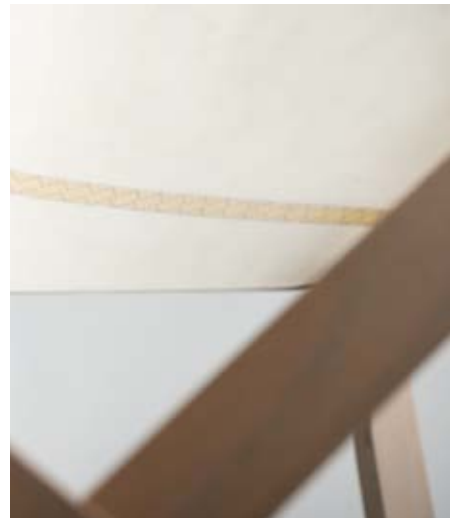



Upcycling,  
economia  
circolare,  
vele di recupero  
diventano sedute  
per l'outdoor,  
stampa sublimatica  
personalizzabile





The Dolcevita regista chair, in its three versions, with and without armrests and stool, is also made with fabrics specifically for outdoor use.

PO01 / PO02

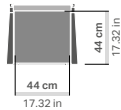
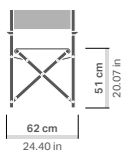

SE01 / SE02

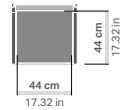
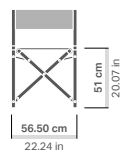

SG01 / SG02

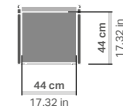
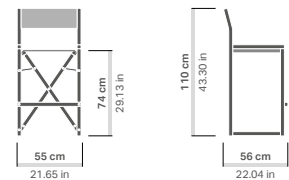

# And soft PLT02

Designed by Alan De La Coba

Fully upholstered lounge chair. "And" is available in a new lounge variant, even softer and more welcoming.

Sinuous lines, enveloping back and even more comfortable seating. "And" is the collection that emboldens you to be experimental and daring, alternating between the manifold functions of the seat

Poltrona lounge completamente imbottita. And si declina in una nuova variante, ancora più morbida e accogliente. Linee sinuose, schienale avvolgente e seduta ancora più comoda. And è la collezione che dà voce alla voglia di sperimentare e osare, spaziando nelle

varie funzionalità delle sedute. Ogni singolo elemento della famiglia ha una propria identità e una propria silhouette, sedute singole per le varianti tonde e anche accostabili nelle varianti squadrate.





**Wrap-  
around  
backrest,  
soft  
volumes,  
green  
upholstery**



[New life](#) | [New products](#) | [And soft](#)

Schienale  
avvolgente,  
volumi  
morbidi,  
rivestimento  
green





Each individual element of the family has its own identity and silhouette; single seats for the round variants but also modular for the square variants.

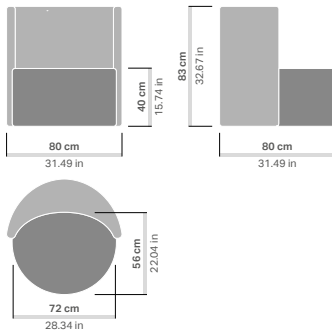

## WOOD ANILINE AND METALS PALETTE

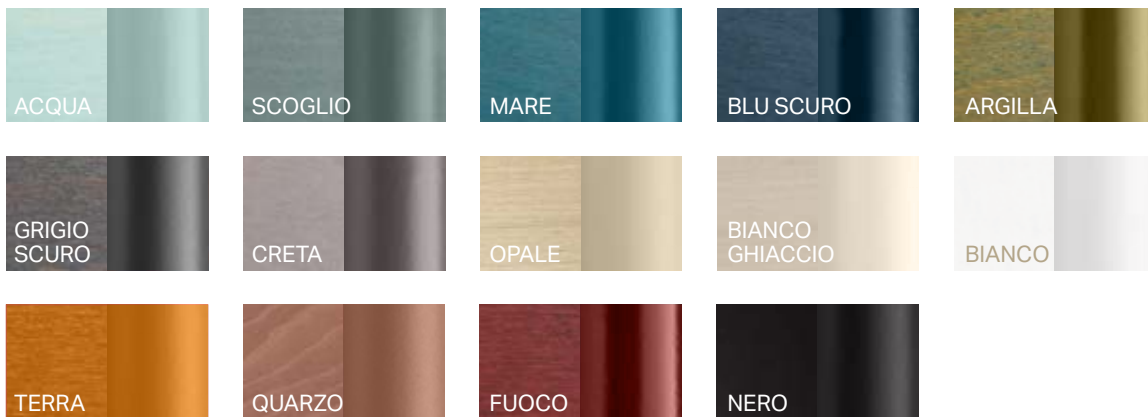

## CLASSIC WOOD COLORS

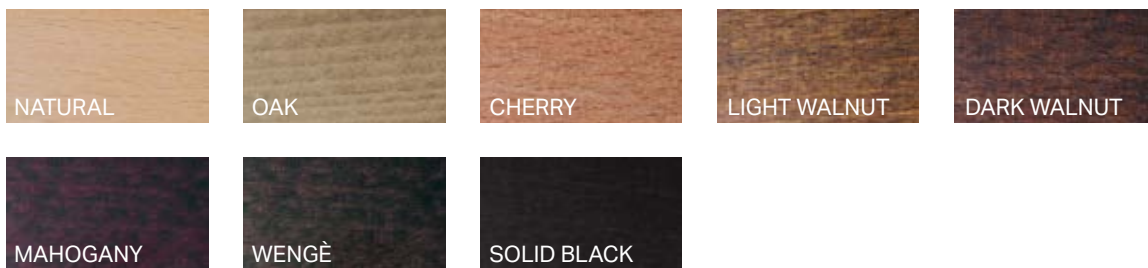

## New Life Finishes Finiture

**Sober and refined nuances, in the colors of classic essences or in the interesting and absolutely exclusive aniline New Life palette, created to satisfy the aesthetic choices of interior and outdoor design.**

**Neutral and delicate or rich and deep tones, in a range where each color complements the other, rendering a measured chromatic balance that has elegance, freshness and modernity.**

**Every nuance is the result of research aimed at giving spaces harmony, identity and continuity.**

Nuance sobrie e raffinate, nei colori delle essenze classiche o nell'interessante e assolutamente esclusiva palette New Life all'anilina, creata per soddisfare le scelte estetiche dell'interior e dell'outdoor design.

Toni neutri e delicati o ricchi e profondi, in una gamma dove ogni colore è complementare all'altro, per offrire un equilibrio cromatico di grande misura, con eleganza, freschezza e modernità.

Ogni nuance è il risultato di una ricerca che tende a dare armonia, identità e continuità agli spazi.





**New Life srl**

Via Sottorive, 5/7 33048  
San Giovanni al Natisone (Udine) Italy

[www.newlifecontract.com](http://www.newlifecontract.com)  
[info@newlifecontract.com](mailto:info@newlifecontract.com)  
phone: + 39 0432 746518



**Inspire. Create. Deliver.**